

MFH500

Flameless Air Heater

Owner's Manual

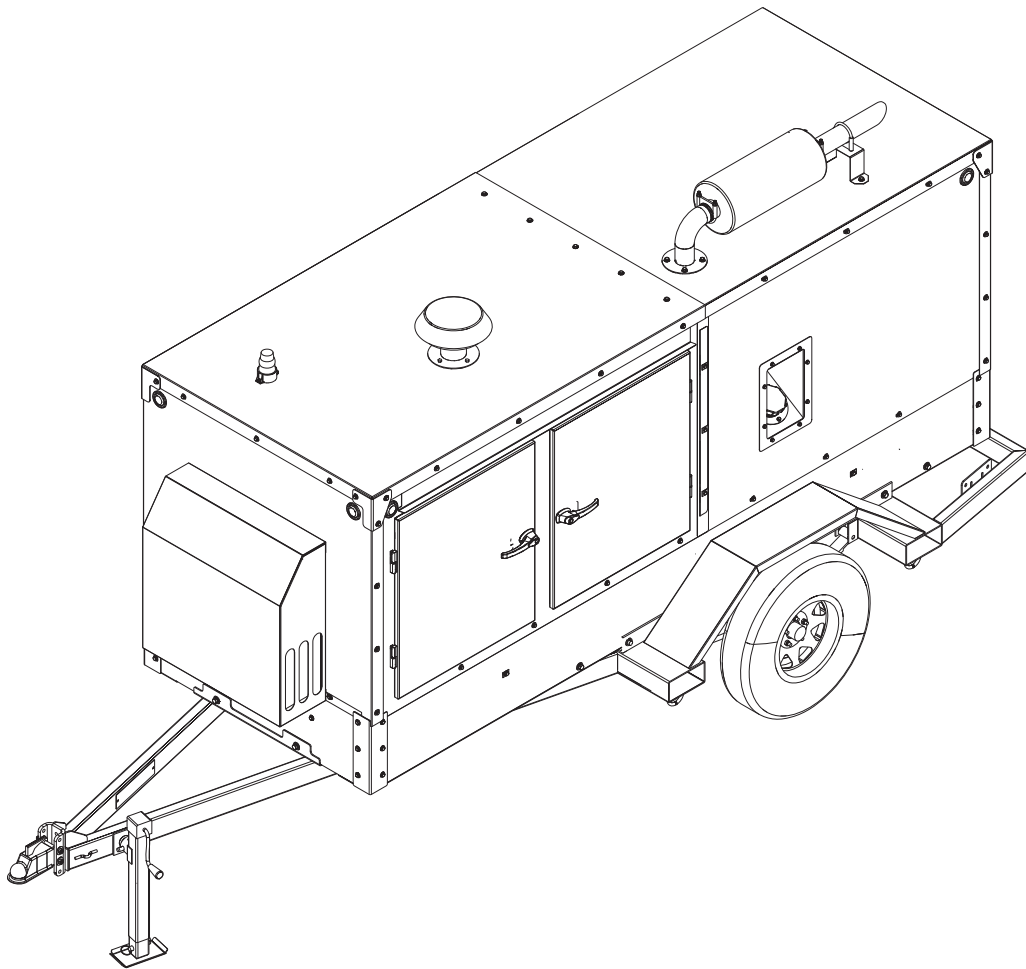

For technical assistance contact:

www.generacmobileproducts.com

Technical Support

1-800-926-9768

SAVE THIS MANUAL FOR FUTURE REFERENCE

Use this page to record important information about your mobile heater

Unit Model No.	
Unit Serial No.	
Engine Model No.	
Engine Serial No.	
Generator Model No.	
Generator Serial No.	

Record the information found on your unit data label on this page. See [Unit Serial Number Locations](#).

Engine and generator serial numbers are located on data plates affixed to the engine and generator, respectively. When contacting a Generac Mobile Authorized Service Dealer (GMASD) about parts and service, always provide the unit model and serial number.

Operation and Maintenance: Proper maintenance and care of the mobile heater ensures a minimum number of problems and keeps operating expenses at a minimum. It is the operator's responsibility to perform all safety checks, to verify that all maintenance for safe operation is performed promptly, and to have the equipment checked periodically by a GMASD. Normal maintenance, service, and replacement of parts are the responsibility of the owner/operator and, as such, are not considered defects in materials or workmanship within the terms of the warranty. Individual operating habits and usage may contribute to the need for additional maintenance or service.

 **WARNING****CANCER AND REPRODUCTIVE HARM**

www.P65Warnings.ca.gov

(000393a)

 **WARNING**

Breathing diesel engine exhaust exposes you to chemicals known to the State of California to cause cancer and birth defects or other reproductive harm.

- Always start and operate the engine in a well-ventilated area.
- If in an enclosed area, vent the exhaust to the outside.
- Do not modify or tamper with the exhaust system.
- Do not idle the engine except as necessary.

For more information go to

www.P65Warnings.ca.gov/diesel (000394)

Table of Contents

Section 1: Introduction and Safety

Introduction	1
Read This Manual Thoroughly	1
Intended Applications	1
Safety Rules	1
How to Obtain Service	2
General Hazards	2
Explosion and Fire Hazards	3
Battery Hazards	3
Service Safety	3
Trailer Hazards	4
Wheel Chock Guidelines	4
Towing Safety	5
Hitch and Coupling	5
Safe Towing Techniques	5
Reporting Trailer Safety Defects	5

Section 2: General Information

Specifications	7
Unit Dimensions	8
Unit Serial Number Locations	8
Component Locations	9
Exterior	9
Interior	10
Engine Oil Recommendations	11
Coolant Recommendation	11
Fuel System	11
Hydraulic Oil	11
Emissions	12
Controller	12
Monitoring, Diagnostic, and Protective Features	12

Section 3: Operation

Placement	13
Lifting the Unit	13
Using the Forklift Pockets	13
Towing the Unit	13
Before Towing Checklist	14
Testing the Breakaway Brake System	14

Before Starting Engine	14
Pre-start Checklist	14
Checking Hydraulic Oil Level	14
Checking Engine Coolant Level	14
Checking Battery	15
Ducting Guidelines	15
Engine and Heater Startup	15
General Overview	15
Operation Procedure	16
Adjusting Heater Output	17
AUTO Mode	17
MANUAL Mode	17
Heater Gauge Displays	17
Fuel Level Warning	18
Heater and Engine Shutdown	18
Automatic Shutdown	18

Section 4: Maintenance

Maintenance	19
Maintenance Tasks	19
Daily Walk Around Inspection	19
Checking Engine Oil Level	19
Draining Fluids—Central Fluid Drain System	20
Refilling Engine Oil	20
Adding Coolant	21
Draining Overfill Containment	21
Removing Water From Fuel	22
Checking Alternator Drive Belt	22
Maintenance Schedule	22
Engine Maintenance Schedule	23
Battery Inspection	25
Battery Installation and Replacement	26
Other Maintenance Checks	26

Section 5: Troubleshooting

General Troubleshooting Guide	27
Digital Controller Status Messages	31

**Section 6: Installation Diagrams and Service
Log**

Engine Harness (1 of 3) 33
Engine Harness (2 of 3) 34
Engine Harness (3 of 3) 35
Trailer Wiring Harness 36
Service Log 37

Section 1: Introduction and Safety

Introduction

Thank you for purchasing a Generac Mobile product. This unit has been designed to provide high-performance, efficient operation, and years of quality use when maintained properly.

The MFH500 flameless air heater is designed and built for sustained reliable heat production in industrial operating conditions and environments. The MFH500 is built to withstand frequent handling under these conditions.

The unit is mounted on a trailer that has forklift pockets and chain attach points on both sides. The fully enclosed design protects the operating components, allowing all-weather storage and operations.

The information in this manual is accurate based on products produced at the time of publication. The manufacturer reserves the right to make technical updates, corrections, and product revisions at any time without notice.

Read This Manual Thoroughly



Consult Manual. Read and understand manual completely before using product. Failure to completely understand manual and product could result in death or serious injury. (000100a)

If any section of the manual is not understood, contact your nearest GMASD, or contact Generac Mobile Customer Service at 800-926-9768, or www.generacmobileproducts.com with any questions or concerns.

The owner is responsible for proper maintenance and safe use of the equipment.

SAVE THESE INSTRUCTIONS for future reference. This manual contains important instructions for the heater that should be followed during installation, operation, and maintenance of the heater and batteries. ALWAYS supply this manual to any individual that will use this machine.

Intended Applications

The machine is designed for industrial use. Examples of intended applications include, but are not limited to:

- Gas and oil exploration
- Utilities and power plants
- Mining
- Construction
- Pipeline projects
- Agricultural applications

Using this machine for applications other than its intended purpose may void the warranty. Examples of misuse include, but are not limited to, using the machine:

- To transport persons or equipment.
- As a tow vehicle.
- As a ladder or work surface.
- During extreme weather.
- Indoors.
- If it is incorrectly serviced or maintained.

Safety Rules

The manufacturer cannot anticipate every possible circumstance that might involve a hazard. The alerts in this manual, and on tags and decals affixed to the unit, are not all inclusive. If using a procedure, work method, or operating technique that the manufacturer does not specifically recommend, verify that it is safe for others and does not render the equipment unsafe.

Throughout this publication, and on tags and decals affixed to the unit, DANGER, WARNING, CAUTION, and NOTE blocks are used to alert personnel to special instructions about a particular operation that may be hazardous if performed incorrectly or carelessly. Observe them carefully. Alert definitions are as follows:



Indicates a hazardous situation which, if not avoided, will result in death or serious injury.

(000001)



Indicates a hazardous situation which, if not avoided, could result in death or serious injury.

(000002)



Indicates a hazardous situation which, if not avoided, could result in minor or moderate injury.

(000003)

NOTE: Notes contain additional information important to a procedure and will be found within the regular text of this manual.

These safety alerts cannot eliminate the hazards that they indicate. Common sense and strict compliance with the special instructions while performing the action or service are essential to preventing accidents.

The operator is responsible for proper and safe use of the equipment. The manufacturer strongly recommends that if the operator is also the owner, to read the owner's manual and thoroughly understand all instructions before using this equipment. The manufacturer also strongly recommends instructing other users to properly start and operate the unit. This prepares them if they need to operate the equipment in an emergency.

How to Obtain Service

When the unit requires servicing or repairs, contact a GMASD for assistance. Service technicians are factory-trained and are capable of handling all service needs. Go to www.generac.com/Service/DealerLocator/ for assistance locating a dealer.

When contacting a GMASD about parts and service, always supply the complete model and serial number of the unit as given on its data decal located on the unit. Record the model and serial numbers in the spaces provided on the inside front cover of this manual.

General Hazards



⚠ DANGER

Asphyxiation. Running engines produce carbon monoxide, a colorless, odorless, poisonous gas. Carbon monoxide, if not avoided, will result in death or serious injury.

(000103)



⚠ DANGER

Hydraulic Fluid Injection. High-pressure, high-temperature hydraulic fluid can pierce skin and cause severe burns. Do not check for leaks with hands. Seek immediate medical attention in case of accident. Failure to protect body accordingly will result in death or serious injury.

(000239)



⚠ DANGER

Asphyxiation. Do not operate unit without a properly functioning exhaust system. Doing so will result in death or serious injury.

(000340)

⚠ WARNING

Personal injury. Do not operate unit during transport. Doing so could result in death, serious injury, or property damage.

(000231a)



⚠ WARNING

Hearing Loss. Hearing protection is recommended when using this machine. Failure to wear hearing protection could result in permanent hearing loss.

(000107)



⚠ WARNING

Moving Parts. Keep clothing, hair, and appendages away from moving parts. Failure to do so could result in death or serious injury.

(000111)



⚠ WARNING

Hot Surfaces. When operating machine, do not touch hot surfaces. Keep machine away from combustibles during use. Hot surfaces could result in severe burns or fire.

(000108)

⚠ CAUTION

Equipment or property damage. Do not block air intake or restrict proper air flow. Doing so could result in unsafe operation or damage to unit.

(000229)

⚠ CAUTION

Unit damage. Do not stop engine before heating unit is cooled. Doing so could result in unit damage.

(000240a)

- **DO NOT** run unit indoors or in an area with poor ventilation. Verify engine exhaust cannot seep into closed rooms or ventilation equipment.
- **DO NOT** clean air filter with gasoline or other types of low flash point solvents.
- **DO NOT** clean internal or external components with gasoline or other types of low flash point solvents.
- **DO NOT** use interior compartments to store cleaning rags, tools, or debris.
- **DO NOT** consume diesel fuels or any other fluids used in this machine.
- Clean up any oil or engine fluid spills immediately. Antifreeze is extremely toxic to animals and humans. Engine oil can damage or contaminate concrete, asphalt, and dirt.
- Shut down the engine if any of the following conditions exist during operation:
 - Noticeable change in engine speed.

- Sparking occurs.
- Engine misfires or there is excessive engine/generator vibration.
- Protective covers are loose or missing.

Explosion and Fire Hazards



⚠ DANGER

Explosion and Fire. Fuel and vapors are extremely flammable and explosive. Add fuel in a well ventilated area. Keep fire and spark away. Failure to do so will result in death or serious injury. (000105)



⚠ DANGER

Explosion and Fire. Fuel and vapors are extremely flammable and explosive. Store fuel in a well ventilated area. Keep fire and spark away. Failure to do so will result in death or serious injury. (000143)



⚠ DANGER

Explosion and Fire. Do not fill fuel tank past full line. Allow for fuel expansion. Overfilling may cause fuel to spill onto engine causing fire or explosion, which will result in death or serious injury. (000214)



⚠ WARNING

Risk of Fire. Unit must be positioned in a manner that prevents combustible material accumulation underneath. Failure to do so could result in death or serious injury. (000147)



⚠ WARNING

Fire risk. Fuel and vapors are extremely flammable. Do not operate indoors. Doing so could result in death, serious injury, or property or equipment damage. (000281)



⚠ WARNING

Explosion and fire risk. Do not smoke near unit. Keep fire and spark away. Failure to do so could result in death, serious injury, or property or equipment damage. (000282)

Comply with regulations the Occupational Safety and Health Administration (OSHA) has established, or with equivalent standards. Also, verify that the unit is applied, used, and maintained in accordance with the manufacturer's instructions and recommendations. Do

nothing that might alter safe application/usage and render the unit in noncompliance with the aforementioned codes, standards, laws, and regulations.

Battery Hazards



⚠ WARNING

Explosion. Do not dispose of batteries in a fire. Batteries are explosive. Electrolyte solution can cause burns and blindness. If electrolyte contacts skin or eyes, flush with water and seek immediate medical attention. (000162)



⚠ WARNING

Risk of burn. Do not open or mutilate batteries. Batteries contain electrolyte solution which can cause burns and blindness. If electrolyte contacts skin or eyes, flush with water and seek immediate medical attention. (000163a)

⚠ WARNING

Accidental Start-up. Disconnect the negative battery cable, then the positive battery cable when working on unit. Failure to do so could result in death or serious injury. (000130)



⚠ WARNING

Vision Loss. Eye protection is required to avoid spray from spark plug hole when cranking engine. Failure to do so could result in vision loss. (000181)

⚠ WARNING

Environmental Hazard. Always recycle batteries at an official recycling center in accordance with all local laws and regulations. Failure to do so could result in environmental damage, death, or serious injury. (000228)

Always recycle batteries in accordance with local laws and regulations. Contact your local solid waste collection site or recycling facility to obtain information on local recycling processes. For more information on battery recycling, visit the Battery Council International website at: <http://batteryCouncil.org>

Service Safety

⚠ CAUTION

Personal injury. Wear appropriate personal protective equipment at all times while operating and servicing unit. Failure to do so could result in personal injury. (000419)

- Before servicing the unit, verify the control power switch is OFF (O), and the negative (-) terminal on the battery is disconnected. **DO NOT** perform even routine service (oil/filter changes, cleaning, etc.) unless all electrical components are shut down.
- Replace all missing and hard to read decals. Decals provide important operating instructions and warn of dangers and hazards.

Trailer Hazards

WARNING

Personal injury. Trailer must be securely coupled to the hitch with the chains correctly attached. Uncoupled or unchained towing could result in death or serious injury. (000233a)

WARNING

Crushing hazard. Verify unit is properly secured and on level ground. An unsecured unit can suddenly roll or move, causing death or serious injury. (000234a)

WARNING

Property or Equipment Damage. Tighten wheel lug nuts after first 50 miles to factory specifications. Failure to do so could result in death, serious injury, property or equipment damage. (000235)

WARNING

Rollover hazard. Unit must be placed on flat, level ground to prevent tipping or rollover. Failure to do so could result in death, serious injury, or property or equipment damage. (000283)

WARNING

Property or equipment damage. Do not alter the trailer. Alterations can damage essential safety items. Doing so could result in death, serious injury, or property or equipment damage. (000285)

Driving a vehicle with a trailer in tow is different than driving the same vehicle without a trailer in tow. Consider the following:

- It takes longer to get up to speed.
- More room is needed to turn and pass.
- More distance is needed to stop.
- The driver is responsible for keeping the vehicle and trailer in control.

While towing, make regular stops to verify the following:

- Coupler is secured and locked to the hitch.
- Electrical connections are made.
- Appropriate slack in the safety chains.
- Appropriate slack in the breakaway switch pull-pin cable.
- Tires are inflated to proper air pressure with no damage or unusual wear to tread or sidewalls.
- Trailer doors are secured and latched.

Other towing guidelines:

- Use your mirrors to verify there is enough room for lane changes or entering/exiting traffic.
- Allow plenty of stopping distance for the trailer and tow vehicle.
- Do not drive faster than the conditions allow.
- A rule of thumb for passing distance is the distance with a trailer is four times the passing distance without a trailer.
- Use lower gears for climbing and descending grades.
- Do not ride the brakes while descending grades; this can cause overheating and potential brake failure.
- Do not apply the tow vehicle brakes to correct extreme trailer swaying. Continued pulling of the trailer, and even slight acceleration, or carefully applying the trailer brakes (using the electronic brake controller) will provide a stabilizing force.

Wheel Chock Guidelines

WARNING

Crushing hazard. Verify unit is properly secured and on level ground. An unsecured unit can suddenly roll or move, causing death or serious injury. (000234a)

- **DO NOT** leave the unit coupled to the tow vehicle, or use the breakaway brake system as a substitute for wheel chocking.
- Select wheel chock according to equipment type and size.
- Always use in pairs and on firm surfaces.
- Chock in direction of grade.
- Chock both sides of wheel if direction of grade is unknown.
- Use wheel chock only after parking brake is applied and tested.
- Center chocks squarely against tread of each wheel.
- Do not drive over wheel chocks.

Towing Safety

Towing a trailer requires care. The trailer and vehicle must be in good condition and securely fastened to each other to reduce the possibility of an accident. Some states require that large trailers be registered and licensed. Contact your local Department of Transportation office to verify license requirements for your particular unit.

Hitch and Coupling

- Verify the hitch and coupling on the towing vehicle are rated equal to, or greater than, the trailer's Gross Vehicle Weight Rating (GVWR).
- Verify the trailer hitch and the coupling are compatible. Make sure the coupling is securely fastened to the vehicle.
- **DO NOT** tow the trailer using defective parts. Inspect the hitch and coupling for wear or damage before every tow.
- To eliminate squeaking, wipe the coupler clean and apply fresh grease each time the trailer is towed.
- Connect safety chains in a crossing pattern under the tongue.
- Before towing the trailer, verify that the weight of the trailer is equal across all tires. On trailers with adjustable height hitches, adjust the angle of the trailer tongue to keep the trailer as level as possible.

Safe Towing Techniques

- Practice turning, stopping, and backing up in an area away from heavy traffic prior to transporting the unit.
- Maximum recommended speed for highway towing is 45 mph (72 km/h). Recommended off-road towing speed is 10 mph (16 km/h) or less, depending on terrain.
- When towing, maintain extra space between vehicles and avoid soft shoulders, curbs, and sudden lane changes.
- Reduce speed before curves, and maintain speed throughout the curve.
- Reduce speed before going over bumps or holes. Keep your foot off the accelerator while going over bumps or holes.

Reporting Trailer Safety Defects

If you believe your trailer has a defect which could cause a crash, injury or death, you should immediately inform the National Highway Traffic Safety Administration (NHTSA) in addition to notifying Generac Mobile.

If NHTSA receives similar complaints, it may open an investigation. If it finds that a safety defect exists in a group of vehicles, it may order a recall and remedy campaign. However, NHTSA cannot become involved in an individual problem between you, your dealer, or Generac Mobile.

To contact NHTSA, you may either call the Auto Safety Hotline toll-free at 1-888-327-4236 (TTY:1-800-424-9153), go to <http://www.safercar.gov>, or write to:

Administrator
NHTSA
1200 New Jersey Avenue S.E.
Washington, DC 20590

You can also obtain other information about motor vehicle safety from <http://www.safercar.gov>

This page intentionally left blank.

Section 2: General Information

Specifications

Description	Unit of Measure	MFH500
Engine		
Make (Model)	—	Isuzu® (4JJ1TT4)
EPA Certification	tier	4 Final
Type	—	turbo, liquid cooled
Horsepower At Operating Speed	hp (kW)	73 (54.4)
Operating Speed	rpm	2,000
Displacement	in ³ (L)	183 (3.0)
Cylinders	qty	4
Fuel Type	—	#1 Diesel [below 32 °F (0° C)], #2 Diesel
Fuel Consumption	gph (Lph)	3.66 (13.9)
Fan	—	18.25 in (46.36 cm) diameter, backward inclined
Capacities		
Minimum Run Time	hr	47 hr
Fuel—Tank, Usable	gal (L)	152 (575)
DEF—Tank, Usable	gal (L)	
HTF—Tank, System	gal (L)	25 (95)
Coolant	qt (L)	6.3 (5.9)
Oil, Including Filter	qt (L)	15.85 (15)
Heater		
Type	—	Flameless, self-contained
Maximum Heat Produced	BTU/hr (kW/hr)	485,000 (220)
Air Output—Temperature Rise	°F (°C)	180 (82)
Air Output—Volume	ft ³ /min (m ³ /hr)	2,650–5,500 (4,502–9,345)
Static Pressure	WG (Pa)	5 (1,245)
Air Ducts	qty, diameter	2, 12 in (30.5 cm)
Estimated Efficiency	%	85%
HTF Pump	type	Hydraulic piston pump
Trailer		
Brakes	Type	Electric
Per-Axle Rating	lb (kg)	6,000 (2,989.2)
Axles	qty	1
Tire Size	in (cm)	16 (40.6)
Hitch	size, type	2-5/16 in, ball coupler
Maximum Tire Pressure	psi (kPa)	80 (551.6)
Electrical		
System Voltage	VDC	24
Battery—Voltage (Quantity Per Unit)	VDC (qty)	12 (2)
Battery—Rating	CCA	950
Battery—Group Number	—	24
Controller, Display	—	IFM CR0403, Murphy PV405
Unit Weight		
Dry	lb (kg)	4,300 (1,950)
Operating	lb (kg)	6,400 (2,903)

Specifications are subject to change without notice.

Unit Dimensions

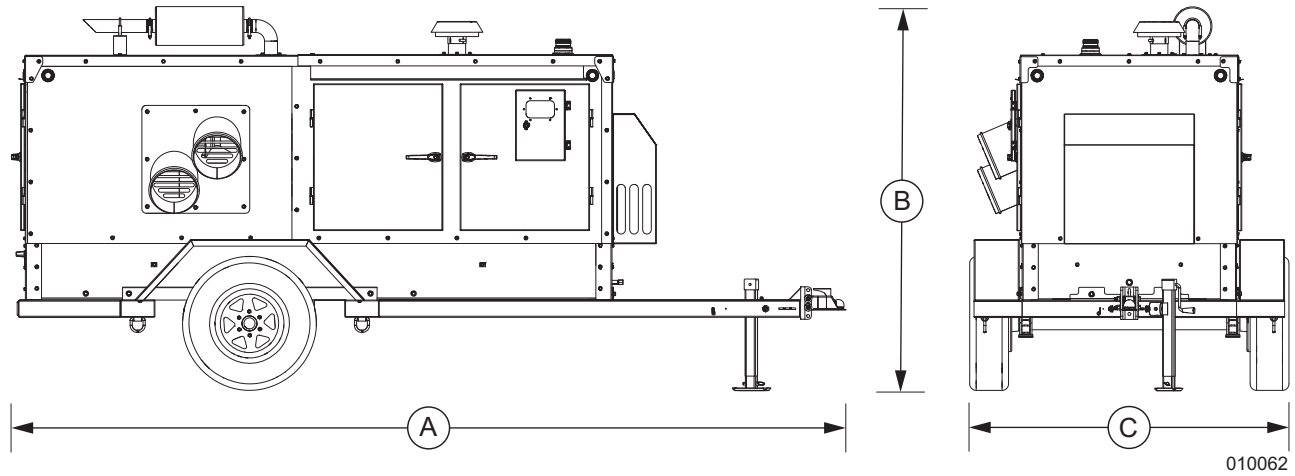

Figure 2-1. MFH500

A	B	C
191 in (4.85 m)	88 in (2.24 m)	72 in (1.83 m)

Unit Serial Number Locations

See [Figure 2-2](#) for unit ID tag and Vehicle Identification Number (VIN) tag. Important information, such as the unit serial number, model number, VIN and tire loading information are found on these tags. Record the

information from these tags so it is available if the tags are lost or damaged. When ordering parts or requesting assistance, you may be asked to provide this information.

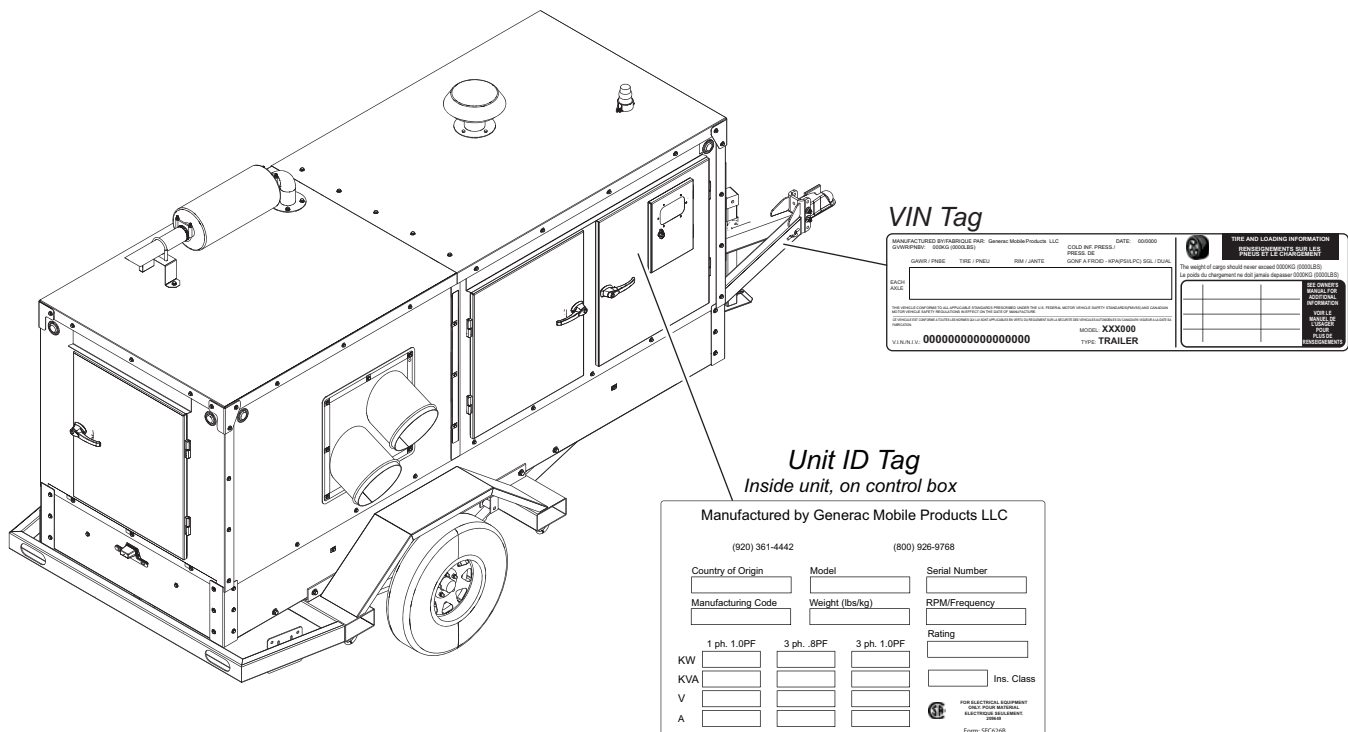

Figure 2-2. Serial Number Locations

Component Locations

Exterior

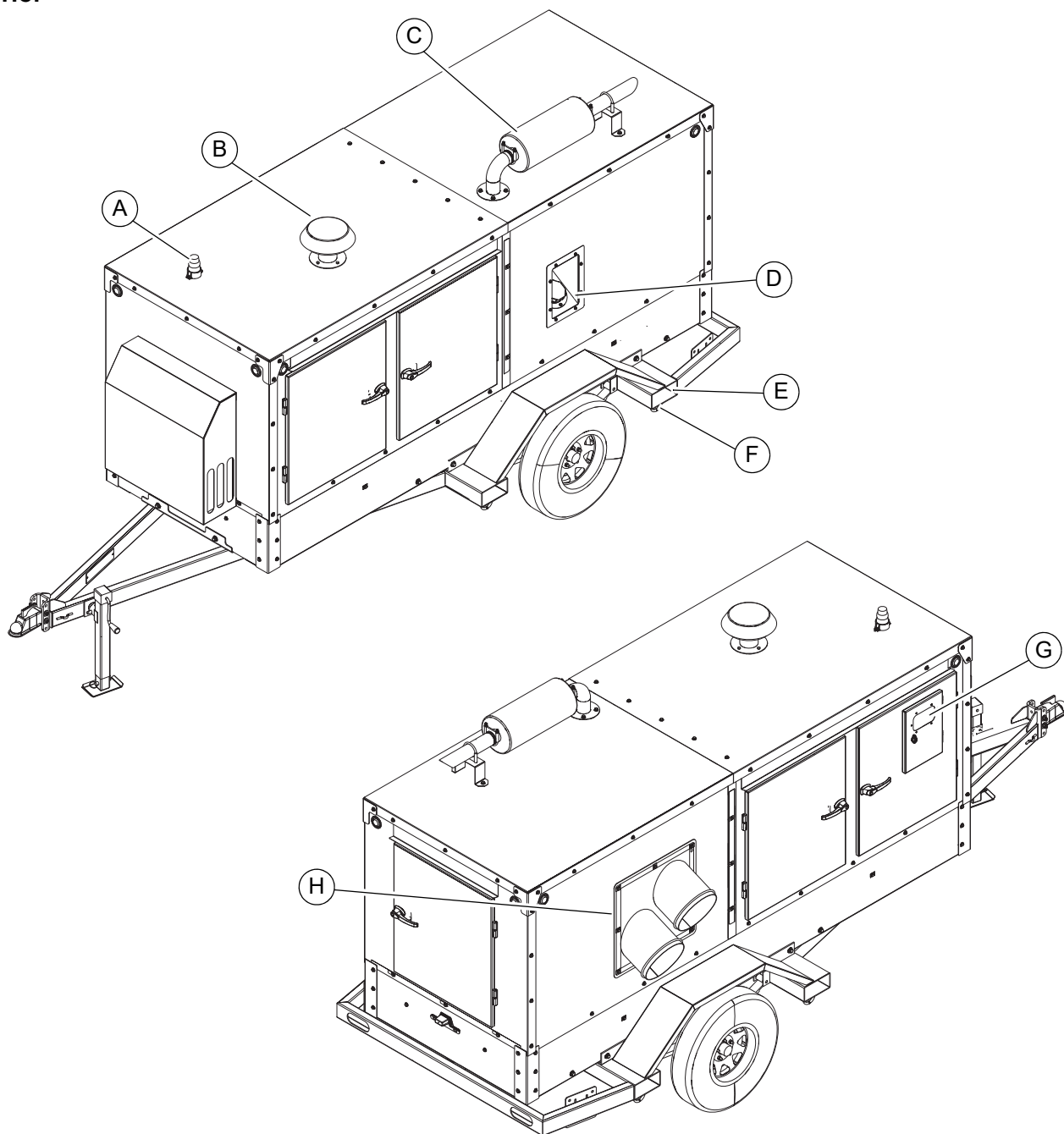

Figure 2-3. Exterior Components

- | | | | |
|---|----------------|---|-------------------------------|
| A | Roof beacon | E | Forklift pocket (4 locations) |
| B | Air intake | F | Tie-down (4 locations) |
| C | Engine exhaust | G | Control panel |
| D | Fuel fill | H | Hot air discharge ducts |

Interior

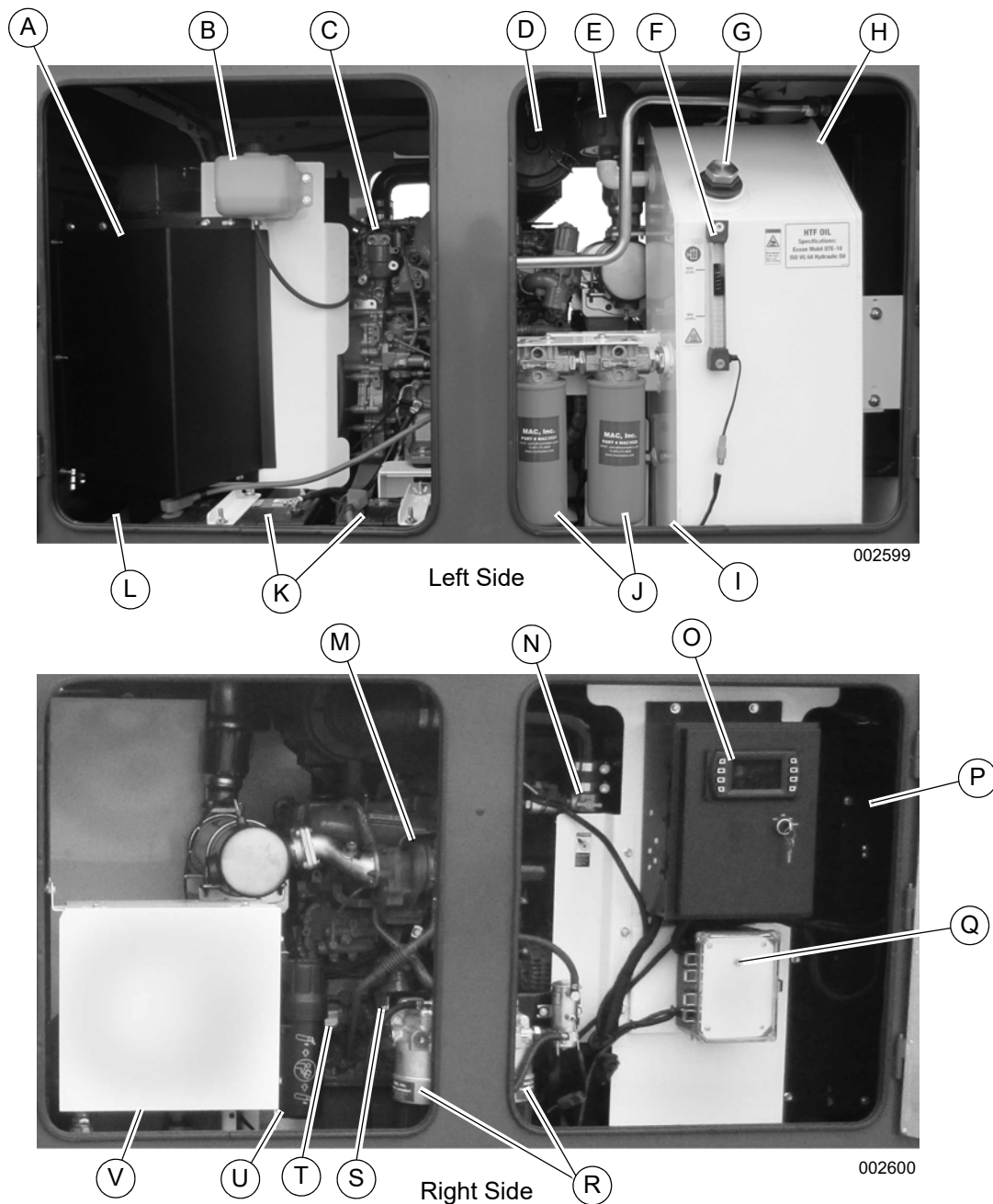

Figure 2-4. Interior Components

- | | |
|--|---------------------------------|
| A Fuel cooler (behind shield) | L Breakaway battery for trailer |
| B Engine coolant reservoir | M Diesel engine turbo charger |
| C Diesel engine | N Positive air shutdown (PAS) |
| D Air cleaner | O Controller |
| E Hydraulic fluid breather | P Radiator and engine fan |
| F Hydraulic fluid level gauge | Q PAS test switch |
| G Hydraulic fluid fill port | R Engine fuel filters |
| H Hydraulic fluid reservoir | S Engine oil filter |
| I Hydraulic fluid drain port (below filters) | T Engine oil fill |
| J Hydraulic fluid filters | U Document holder |
| K Batteries | V 63cc pump (behind shield) |

Engine Oil Recommendations

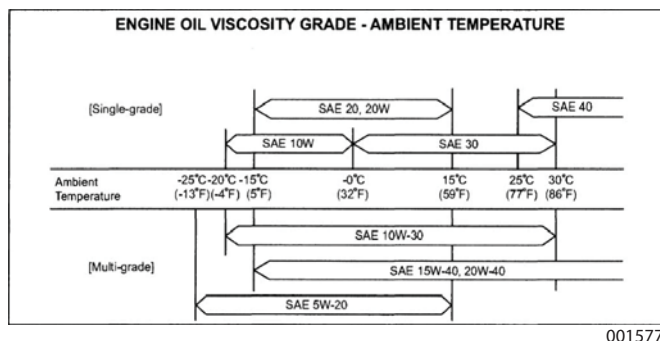

Figure 2-5. Isuzu 4JJ1 Engine Oil Recommendations

NOTE: For temperatures below -13 °F, use SAE 5W-30. For more information, see the engine manual.

Coolant Recommendation



⚠ DANGER

Risk of poisoning. Do not use mouth to siphon coolant. Doing so will result in death or serious injury.

(000149)

⚠ CAUTION

Engine damage. Use approved coolant only. Failure to do so could result in equipment damage.

(000323)

Where the atmospheric temperature falls below freezing, the cooling system should be drained after engine operation. To eliminate the need for repeated draining and refilling, the use of a 50/50 ethylene glycol base antifreeze/water mix is recommended. Never exceed a 60/40 antifreeze/water mix. Use demineralized or distilled water for best results. Hard water causes scale deposits, which reduces cooling efficiency and raises internal temperatures, possibly leading to engine damage.

NOTE: Recommended coolant is ZEREX™ Nitrate Free Extended Life Antifreeze/Coolant.

NOTE: Normal coolant operating temperature is 167–194 °F (75–90 °C).

Freezing Point °F (°C)	3 (-16)	-13 (-25)	-31 (-35)	-58 (-50)
Coolant (% Volume)	30	40	50	60
Water (% Volume)	70	60	50	40

For more information, see the engine manual.

Fuel System



⚠ DANGER

Explosion and Fire. Fuel and vapors are extremely flammable and explosive. Keep fire and spark away. Failure to do so will result in death or serious injury.

(000168)



⚠ DANGER

Explosion and Fire. Do not overfill fuel tank. Overfilling may cause fuel to leak and ignite or explode, resulting in death or serious injury.

(000204)



⚠ WARNING

Explosion and Fire. Do not smoke while refueling unit. Failure to do so could result in death, serious injury, or property or equipment damage.

(000284a)

The machine is designed to operate with diesel fuel.

IMPORTANT NOTE: Comply with all laws and regulations concerning the storage and handling of fuels.

Follow these guidelines:

- Use only ultra-low-sulfur diesel fuel.
- When temperatures are at or below freezing, use No. 1D diesel fuel.
- When temperatures are above freezing, use No. 2D diesel fuel.
- In some areas of the country, climatized fuel—a mixture of 1D and 2D, may also be used.
- **DO NOT** use home heating oil or gasoline; either may cause engine damage.
- **DO NOT** use fuel additives, other than the recommended biocide. Smoke suppressant additives are not recommended.

Hydraulic Oil



⚠ DANGER

Hydraulic Fluid Injection. High-pressure, high-temperature hydraulic fluid can pierce skin and cause severe burns. Do not check for leaks with hands. Seek immediate medical attention in case of accident. Failure to protect body accordingly will result in death or serious injury.

(000239)

Type: Exxon Mobile DTE-10 ISO VG 68 hydraulic oil.

See [Maintenance](#) for more information.

Emissions

The United States Environmental Protection Agency (US EPA) (and California Air Resources Board (CARB), for engines/equipment certified to California standards) requires this engine/equipment to comply with exhaust and evaporative emissions standards. Locate the emissions compliance decal on the engine to determine applicable standards. See the included emissions warranty for emissions warranty information. Follow the maintenance specifications in this manual to ensure the engine complies with applicable emissions standards for the duration of the product's life.

Controller

For troubleshooting, see [Digital Controller Status Messages](#).



001576

Figure 2-6. Controller

Button ID	Manual Mode	Auto Mode
A	Increase heat	Increase temperature setting
B	Increase fan	Decrease temperature setting
C	Overview/Analog gauge screen	
D	Main menu	
E	Heater on/off	
F	Next screen	
G	Popup "Softkeys"	

Monitoring, Diagnostic, and Protective Features

Mechanical and electrical systems are connected to various sensors that monitor unit status. If conditions occur outside of predetermined manufacturing parameters, the controller will automatically stop the machine and display fault information. The controller can also display a variety of critical alerts, diagnostics, and recommendations. The controller provides a variety of real-time current operating condition data on outlet temperature, engine rpm, and fuel level. For more information, refer to the controller wiring diagrams.

Section 3: Operation

Placement



⚠ DANGER

Asphyxiation. Running engines produce carbon monoxide, a colorless, odorless, poisonous gas. Carbon monoxide, if not avoided, will result in death or serious injury.

(000103)



⚠ WARNING

Fire risk. Fuel and vapors are extremely flammable. Do not operate indoors. Doing so could result in death, serious injury, or property or equipment damage.

(000281)

⚠ WARNING

Rollover hazard. Unit must be placed on flat, level ground to prevent tipping or rollover. Failure to do so could result in death, serious injury, or property or equipment damage.

(000283)



⚠ WARNING

Risk of Fire. Unit must be positioned in a manner that prevents combustible material accumulation underneath. Failure to do so could result in death or serious injury.

(000147)

NOTE: Before placement, become familiar with local, state, or national codes and regulations regarding the placement of diesel powered flameless air heaters.

1. Position the unit on a flat, level surface. Position the unit a minimum of 5 ft (1.5 m) from structures or barricades. Surface must be stable and dry. See [General Hazards](#) for more guidelines.
2. Verify that exhaust vapors or fumes will not enter buildings, enclosed areas, workspaces, open windows or doors, or any other structure. Proper ventilation is essential to avoiding carbon monoxide poisoning.
3. Place wheel chocks as required in [Wheel Chock Guidelines](#). **DO NOT** position the unit on a grade or slope. **DO NOT** rely on the tow vehicle to hold the unit in place.

NOTE: Verify the unit has been uncoupled from the tow vehicle before operation.

Lifting the Unit

The unit is equipped with forklift pockets. These can be used to lift and position the machine.

Using the Forklift Pockets

⚠ WARNING

Personal injury. Excessive weight. Use only appropriate lifting eyes and lifting equipment to lift unit. Improper lifting techniques could result in equipment damage, death or serious injury.

(000224)

IMPORTANT NOTE: Verify the work area and unit are clear of people and debris that may interfere with, or be injured by, lifting and placing the unit.

1. Verify the lifting equipment is suitable for lifting the load. See [Specifications](#) for more information.
2. See [Figure 3-1](#). Insert the forklift prongs into the forklift pockets (A) on the unit.

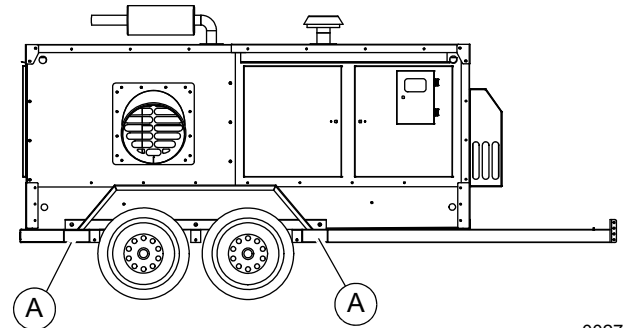

002737

Figure 3-1. Tandem Axle (Optional) Forklift Pockets

3. Raise the unit a small distance and assess stability.

NOTE: If stability is in question, lower the unit to the ground and adjust the lifting device. Verify the lifting equipment is suitable for the load. Repeat steps 1–3 until stability is established.

4. Continue lifting to desired height once stability is established.

Towing the Unit

⚠ WARNING

Personal injury. Trailer must be securely coupled to the hitch with the chains correctly attached. Uncoupled or unchained towing could result in death or serious injury.

(000233a)

TBW instructions on towing the unit. (How to attach coupling) Is this transported on a flat bed to deliver? Need instructions on that?

Before Towing Checklist

- Verify breakaway brake battery is fully charged.
- Test the breakaway brake system before each use.
- Perform a visual check of the trailer and tires for safety issues or damage.
- Verify the trailer tires are properly inflated, with no uneven wear.
- Wheel lug nuts are tightened to 85–95 ft-lbs (115–129 Nm).
- Verify all safety chains and features are properly connected between the tow vehicle and the trailer.
- Verify all trailer jacks are raised and secured once the trailer is safely attached to the tow vehicle.
- Verify all doors and enclosures are closed and locked.
- Verify all safety lights (brake lights, blinkers, etc.) on the tow vehicle and trailer are in working order.
- Verify brake controller engages the trailer brakes before the tow vehicle brakes.
- Verify the vehicle is rated for the Gross Vehicle Weight Rating (GVWR) of the trailer.
- Plan any trip beforehand and verify the tow vehicle and trailer will be able to pass under all vertical obstacles such as bridges, overpasses, tunnels, and overhangs.

Testing the Breakaway Brake System

TBW, procedure on testing operation of the breakaway brake system.

- **DO NOT** use the breakaway brake system as a substitute for wheel chocking.

Before Starting Engine



WARNING

Hot Surfaces. When operating machine, do not touch hot surfaces. Keep machine away from combustibles during use. Hot surfaces could result in severe burns or fire.

(000108)

Pre-start Checklist

- Remove all flammable materials and fire hazards within 5 ft (1.5 m) of heater.
- Verify unit is not leaking fluids: check inside and outside the unit for leaking fuel, engine oil, HTF/hydraulic oil, and engine coolant. **DO NOT** use any equipment that is leaking fluids!
- Verify the following are clear of debris and obstructions:
 - Engine air intake
 - Engine exhaust stack

– Outlets and fan intakes

- Verify air duct hose is securely fastened to outlet duct assembly.
- Verify all inlet and outlet ducts are open and uncovered.
- Check fluid levels. See the following:
 - [Checking Engine Oil Level](#)
 - [Checking Hydraulic Oil Level](#)
 - [Checking Engine Coolant Level](#)
- Verify unit is properly secure with jacks deployed (if applicable), wheels chocked, and is level.
- Check alternator drive belt for tension and wear.
- Verify all scheduled maintenance has been performed BEFORE starting or operating unit. See [Maintenance Schedule](#).

Checking Hydraulic Oil Level

1. See [Figure 3-2](#). Verify hydraulic oil level is between MIN and MAX on the hydraulic oil level gauge (A).

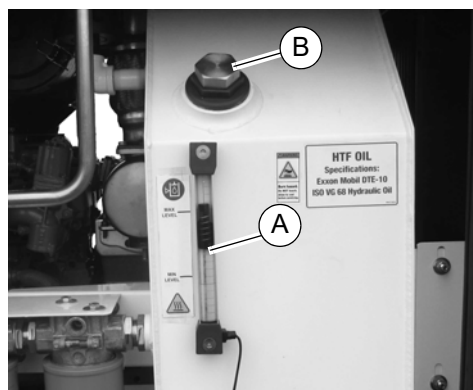

Figure 3-2. Hydraulic Oil Gauge

2. If hydraulic oil level is lower than MIN, add hydraulic oil through the hydraulic fluid fill port (B). See [Hydraulic Oil](#).

Checking Engine Coolant Level



WARNING

Risk of burns. Do not open coolant system until engine has completely cooled. Doing so could result in serious injury.

(000154)

1. Remove radiator fill cap.
2. Check coolant level and degree of fouling.
 - Coolant level should be approximately 0.39 in (10 mm) below the radiator core top.
 - If coolant levels are insufficient, see [Adding Coolant](#).
3. Install radiator cap securely.

Checking Battery



⚠️ WARNING

Electrical shock. Disconnect battery ground terminal before working on battery or battery wires. Failure to do so could result in death or serious injury.

(000164)



⚠️ WARNING

Risk of burn. Do not open or mutilate batteries. Batteries contain electrolyte solution which can cause burns and blindness. If electrolyte contacts skin or eyes, flush with water and seek immediate medical attention.

(000163a)



⚠️ WARNING

Explosion. Batteries emit explosive gases while charging. Keep fire and spark away. Wear protective gear when working with batteries. Failure to do so could result in death or serious injury.

(000137a)



⚠️ CAUTION

Equipment damage. Do not make battery connections in reverse. Doing so will result in equipment damage.

(000167a)

1. Verify battery cable connections are not loose or corroded.
2. Verify battery electrolyte level is sufficient. If necessary, replenish with a commercially available electrolyte, such as distilled water.

Ducting Guidelines



⚠️ DANGER

Asphyxiation. Running engines produce carbon monoxide, a colorless, odorless, poisonous gas. Carbon monoxide, if not avoided, will result in death or serious injury.

(000103)

⚠️ WARNING

Burn hazard. Do not remove ducting until all air pressure has been emptied from hose duct. Failure to do so could result in severe injury.

(000288)

- Place ducting in desired configuration before operating the unit.
- Tightly secure ducting ends to the unit.
- Avoid sharp bends or 90° turns in the ducting.

- Use only the necessary length of ducting required; do not exceed maximum length.
- **DO NOT** leave any input or output ports closed during operation. All ports must remain open, even if they are unused, to avoid static air buildup.
- **DO NOT** place ducting over combustible materials.
- **DO NOT** place ducting over surfaces that may damage it or reduce performance, such as water, sharp rocks or glass, electrical wiring, piping, etc.
- **DO NOT** place or drape anything over ducting, such as covers, insulation (insulated ducting is available), blankets or cloth, electrical wires, etc.

Engine and Heater Startup

⚠️ WARNING

Equipment damage. Do not attempt to start or operate a unit in need of repair or scheduled maintenance. Doing so could result in serious injury, death, or equipment failure or damage.

(000291)

⚠️ CAUTION

Equipment damage. Do not use starting aids in the engine air intake system. Such aids can cause immediate engine damage.

(000289)

⚠️ CAUTION

Equipment or property damage. Do not block air intake or restrict proper air flow. Doing so could result in unsafe operation or damage to unit.

(000229)

⚠️ CAUTION

Equipment damage. Do not cover unit during operation. All ducting ports must remain open even if not being used. Failure to do so will result in equipment damage.

(000290)

General Overview

The heater and fans start automatically. Initial heater start-up is based on coolant temperature. Heater and fan behavior are then driven by several user-defined benchmarks. Once the engine has warmed, the process works as follows:

1. The heat coil energizes, raising the heat current to the value in the min current field on the Heat Settings screen.
2. The unit maintains the min current for the amount of time entered in the startup delay field. The heat

current then rises to the value in the Max Current field.

3. The unit reads the value in the startup delay field on the fan settings screen when max current is reached, and begins counting it down.
4. The fans switch on when the startup delay expires, ramping up to the value in the min current field.
5. Heat begins blowing from ducts when the heater is warm.

Operation Procedure

Proceed as follows to operate the unit:

1. Perform **Pre-start Checklist**.
2. Close all doors that access the unit’s interior.

IMPORTANT NOTE: All doors on the unit must be closed during operation.

3. See **Figure 3-3**. Turn ignition key switch to ON. The screen displays “Engine Preheat”. Keep ignition key switch to ON until glow plug indicator turns off.

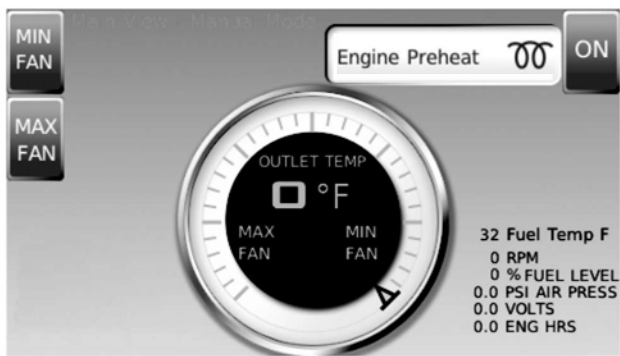

Figure 3-3. Engine Preheat

CAUTION

Equipment Damage. Do not continuously crank engine for more than ten seconds. Doing so will lead to overdischarge of batteries and starter seizure.

(000230)

4. See **Figure 3-4**. When screen displays “Start Engine”, turn ignition key switch to START. Release ignition key switch once engine starts.

NOTE: If the engine cannot be started in a one time attempt, rest the batteries and the starter for at least 30 seconds, then repeat the pre-heating and starting operations.

CAUTION

Equipment damage. Continuous engagement of the starter to the flywheel ring gear without intermission will result in damage to the starter pinion gear and flywheel ring gear. (000292)

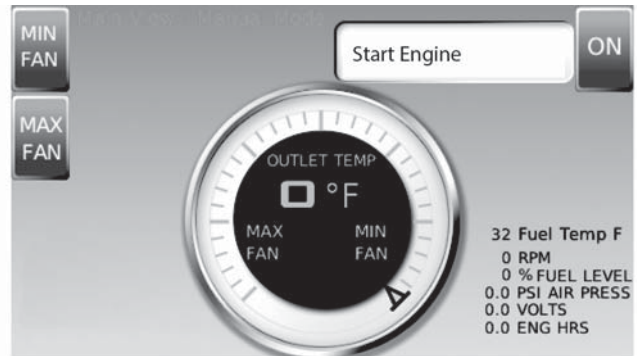

Figure 3-4. Start Engine

5. See **Figure 3-5**. The screen displays “Engine Warming – Please Wait”.



Figure 3-5. Engine Warming

6. See **Figure 3-6**. When the coolant temperature reaches 140 °F (60 °C), engine warming is complete and the heater automatically begins warming up. The screen displays “Heater is warming up--Please wait”.

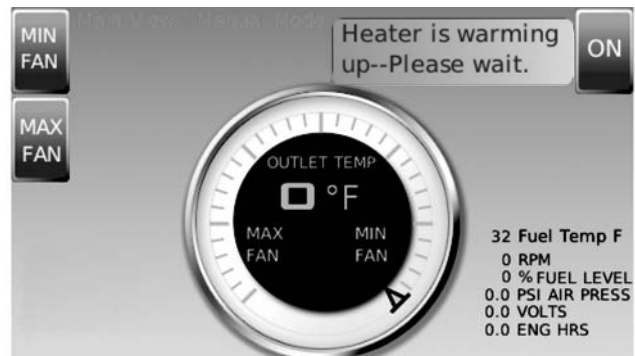

Figure 3-6. Heater Warming

7. See [Figure 3-7](#). When the heater is warm, heat begins blowing from ducts and the screen displays “Heater On--Press Off to stop the heater”.



001586

Figure 3-7. Heater On

NOTE: The heater is now operational. The green beacon on top of the machine begins flashing.

8. Adjust heater output as desired. See [Adjusting Heater Output](#).

Adjusting Heater Output

Output temperature is directly related to the rpm of the fan: the higher the output temperature, the lower the rpm of the fan. Fan rpm impacts how much area is heated: higher fan rpm results in a larger area heated.

How to adjust the heater output depends on what mode is used. The heater has two modes—AUTO and MANUAL. The current mode displays at the top of the controller screen.

AUTO Mode

In AUTO mode, output temperature is manually set, as follows:

- To increase output temperature, press (+) ([Figure 3-8](#), item A).
- To decrease output temperature, press (-) ([Figure 3-8](#), item B).



001578

Figure 3-8. AUTO mode

MANUAL Mode

In MANUAL mode, heater output can be set to minimum fan or maximum fan, as follows:

- For minimum fan, press MIN FAN ([Figure 3-9](#), item A). Minimum fan increases heat output.
- For maximum fan, press MAX FAN ([Figure 3-9](#), item B). Maximum fan reduces heat output.



001579

Figure 3-9. MANUAL mode

Heater Gauge Displays

Proceed as follows to activate the gauge display to monitor operation parameters:

- Press the third button (A) from the top on the left side of the control panel to access the machine overview screen to monitor the operation of the heater.



001578

Figure 3-10. Controller

- Press the button a second time to access the throttle control for the heater.

NOTE: Faults will be displayed in the upper right hand window in red lettering.

The machine overview will show the operation of the heater. If any of the wording is in red, it will relate to a fault on the heater.

- Press the button on the lower left hand corner to access the main menu of the controller screen.

Fuel Level Warning

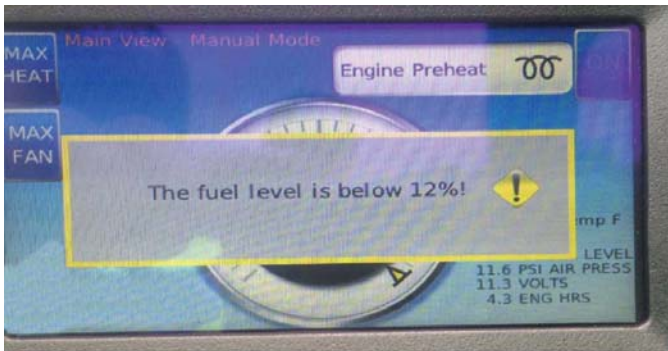

008716

Figure 3-11. Fuel Warning Alert

- The window will appear when fuel level gets below 12%.
- The unit will run for three hours in normal operation, then the heater side of the unit will shut down.
- The engine will run an additional 15 minutes before shutting down.

Heater and Engine Shutdown



Unit damage. Do not stop engine before heating unit is cooled. Doing so could result in unit damage.

(000240a)

1. See **Figure 3-12**. Press OFF to stop the heater (**Figure 3-9**, item C). The screen displays “Heater is cooling down--Please wait”.



001582

Figure 3-12. Heater Cooling

NOTE: During cool down, the ON button is disabled.

2. When cool down is complete, the screen displays as shown in **Figure 3-13**.

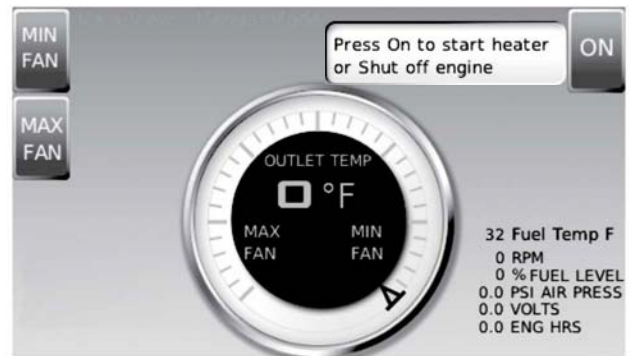

001583

Figure 3-13. Cool-down Complete

3. When the control screen indicates it is safe to turn off the engine, turn the ignition key switch to OFF.

NOTE: Leaving the ignition key switch in the ON position when the engine has been stopped will discharge the batteries over time.

Automatic Shutdown

This unit is equipped with a low oil pressure and high coolant temperature automatic shutdown system. This system will automatically shut off the fuel supply to stop the engine if oil pressure drops too low or the engine exceeds normal operating temperature. Return the control power switch to OFF (O) to reset the unit after you have determined the cause of the shutdown.

Section 4: Maintenance

Maintenance

Regular maintenance will improve performance and extend engine/equipment life. Generac Mobile recommends that all maintenance work be performed by a GMASD. Regular maintenance, replacement, or repair of the emissions control devices and systems may be performed by any repair shop or person of the owner's choosing. To obtain emissions control warranty service free of charge, the work must be performed by a GMASD. See the emissions warranty.

NOTE: Normal maintenance, service, and replacement of parts is the responsibility of the owner and are not considered defects in materials or workmanship within the terms of the warranty. It is strongly recommended that equipment be periodically checked by a GMASD.

Maintenance Tasks

Daily checks must be performed when the unit is operated continuously for extended periods of time. Daily checks and routine monthly checks can be performed by an authorized operator.

Daily Walk Around Inspection

Look for conditions that could hinder performance or safety, such as (but not limited to) oil, coolant, and fuel leakage, blocked vents, loose or missing hardware, and improper electrical connections. Check for foreign matter blocking the vents and on top of unit.

- Inspect outer cover for significant damage beyond scuffs and small nicks.
- Inspect for wire abrasion.
- Inspect the fan belt for cracks, fraying, and stretching. Verify the belt is properly seated in the pulley grooves.
- Check coolant.
- Check electrical connectors, battery, and ground points. Look for loose or missing hardware.
- Check all flexible rubber hoses for deterioration.
- Check hydraulic hoses for signs of wear, such as swelling, softening, cracks, or cuts.
- Verify hoses are not crushed, twisted, or bent to restrict fluid flow.
- Verify there are no cracks or corrosion on the body or the trailer.

Checking Engine Oil Level



Engine damage. Verify proper type and quantity of engine oil prior to starting engine. Failure to do so could result in engine damage.

(000135)

NOTE: Only perform this procedure once unit has cooled. Do not perform maintenance on a hot or operating machine.

1. See [Figure 4-1](#). Remove oil dipstick (A) and wipe it dry with a clean, lint free cloth.

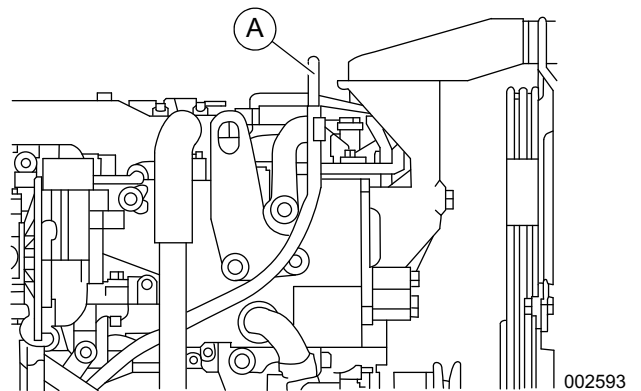

Figure 4-1. Oil Dipstick

2. Slowly insert the clean oil dipstick into the oil dipstick tube. Verify the oil dipstick is fully seated in the oil dipstick tube.
3. See [Figure 4-2](#). After 10 seconds, remove the oil dipstick and look at the oil level on both sides. The lower of the two readings will be the correct oil level measurement. Oil level must be between the MAX (B) and MIN (C) marks.

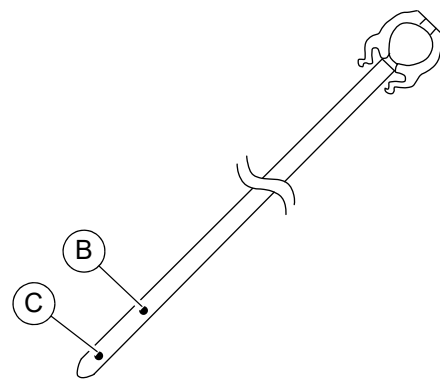

Figure 4-2. Oil Dipstick Reading

002594

4. Add oil if necessary to adjust the level. After adding or changing the oil, the engine should run for one minute before checking the oil level. Wait 10 minutes to allow the engine to cool and oil to fully drain into the oil pan. See [Engine Oil Recommendations](#).

Typical causes of inaccurate oil level readings:

- Reading the high level of the oil dipstick.
- Reading the oil dipstick before the oil fully drains into the oil pan.
- Inserting and removing the oil dipstick too quickly.
- The oil dipstick is not fully seated in the oil dipstick tube.

Draining Fluids—Central Fluid Drain System

See [Figure 4-3](#). This unit is equipped with a *central fluid drain system*. Engine oil, engine fuel, engine coolant, and hydraulic oil; all drain through one drain port (A).

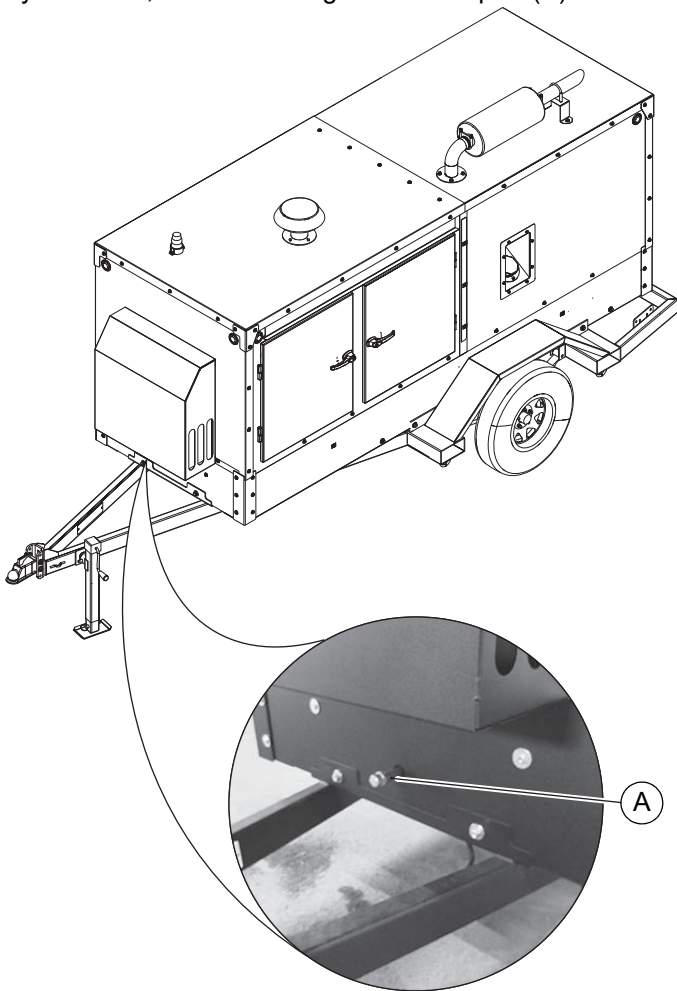

Figure 4-3. Drain Port—Engine Oil, Diesel Fuel, Engine Coolant, and Hydraulic Oil

To drain a fluid:

IMPORTANT NOTE: Drain one fluid at a time.



WARNING

Risk of burns. Allow engine to cool before draining oil or coolant. Failure to do so could result in death or serious injury.

(000139)

WARNING

Potential of cancer. Prolonged or repeated contact with used motor oil has been shown to cause cancer in laboratory animals. Thoroughly wash exposed areas with soap and water.

(000127a)

1. Verify unit is off and interior components are cool.
2. Verify all ball valves are closed.
3. Place suitable container under exterior drain port.
4. Remove plug from exterior drain port.
5. Open ball valve for fluid being changed. For example, the engine oil drain port.

IMPORTANT NOTE: Drain one fluid at a time—do not open more than one ball valve.

6. Allow fluid to drain.
7. When fluid has drained, close ball valve and install exterior drain plug removed in step 4.
8. On the controller, reset the service interval.

Refilling Engine Oil

1. Verify that oil drain valve has been closed.
2. Remove the oil dipstick before adding oil. Oil drains more quickly into the oil pan with the oil dipstick removed.
3. Wipe the area around the oil filler cap clean, so that no foreign particles enter.
4. Remove the oil filler cap.
5. Fill the engine oil pan with fresh oil through the oil filler port. A funnel can be used if desired. **DO NOT overfill.** See [Engine Oil Recommendations](#).

NOTE: Pour the oil slowly to avoid spills. Clean up any spills immediately. Oil stains can ignite and cause engine damage.

6. Wait 15 minutes for oil to reach the oil pan.
7. Check the oil level with the oil dipstick. See [Checking Engine Oil Level](#).

NOTE: Wash skin thoroughly if it comes into contact with used engine fluids.

Adding Coolant



DANGER

Risk of poisoning. Do not use mouth to siphon coolant. Doing so will result in death or serious injury.

(000149)



WARNING

Risk of burns. Do not open coolant system until engine has completely cooled. Doing so could result in serious injury.

(000154)

CAUTION

Risk of overheating. Do not use any chromate base rust inhibitor with propylene glycol base antifreeze, boosters, or additives. Doing so will cause overheating and possible equipment damage.

(000165a)

If coolant level is below the filler neck, coolant needs to be added (see [Coolant Recommendation](#)).

1. Verify engine is stopped and cooled.
2. Remove radiator cap.
3. Fill radiator slowly with coolant until it reaches the filler neck.
4. Operate engine approximately five minutes at a low idle speed to bleed the air in the coolant circuit.

NOTE: Coolant level will drop.

5. Stop engine. Allow it to cool and add coolant as needed.

Draining Overfill Containment



WARNING

Hot Surfaces. When operating machine, do not touch hot surfaces. Keep machine away from combustibles during use. Hot surfaces could result in severe burns or fire.

(000108)

CAUTION

Personal injury. Wear appropriate personal protective equipment at all times while operating and servicing unit. Failure to do so could result in personal injury.

(000419)

To drain the overfill containment:

IMPORTANT NOTE: Only perform this procedure once unit has cooled. Do not perform maintenance on a hot or operating machine.

1. See [Figure 4-4](#). Locate the threaded plug at the front and underneath the unit (A).

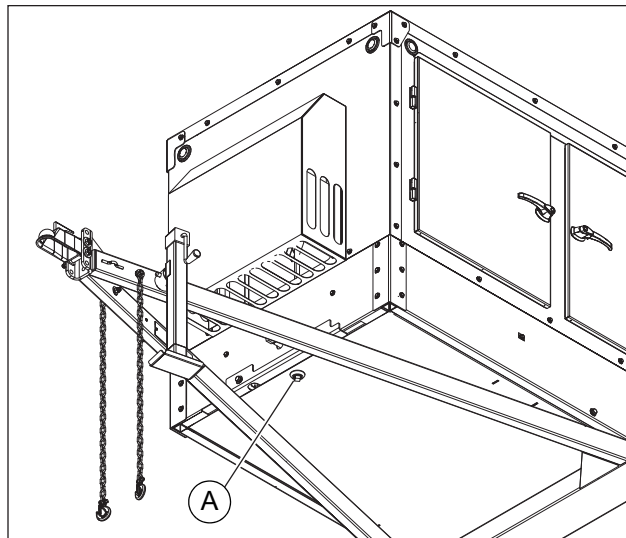

Figure 4-4. Overfill Containment Plug

2. Place a suitable container below the threaded plug.
3. Remove the threaded plug and drain the fluid into the container.
4. Insert the threaded plug once draining has stopped and tighten the plug.
5. Dispose of the container according to local, state, or national regulations pertaining to used engine oil.

NOTE: Wash skin thoroughly if it comes into contact with used engine fluids.

Check the overfill containment system often. Excessive fluid collection and draining can be a sign of engine problems or leaks.

Removing Water From Fuel

A water sedimenter is provided to separate the water contained in the fuel.

The sedimenter housing contains a float that moves up and down in accordance with level change of the separated water. Be sure to drain the separated water when the float comes up to the aluminum body part.

Proceed as follows to drain the water sedimenter:

1. Loosen the air bleeding plug at the top of the water sedimenter, and then loosen the drain plug at the bottom of the case.
2. Drain the water into a suitable container, and dispose of it.
3. After draining, tighten the air bleeding plug and the drain plug.

NOTE: Do not over-tighten the air bleeding plug.

- Torque: 69.9–103.6 **in-lbs** (7.9–11.7 Nm)

NOTE: Do not use an alcoholic water remover. Alcohol may cause plastic parts to crack. This results in low visibility of fuel level or fuel leakage in some cases.

Checking Alternator Drive Belt

IMPORTANT NOTE: Verify that the engine is stopped and cannot be operated during alternator drive belt check.

1. See **Figure 4-5**. Apply pressure to the alternator drive belt with the thumb (22 lb [98 N] pressure), at the midway point between the alternator pulley and the idler pulley.

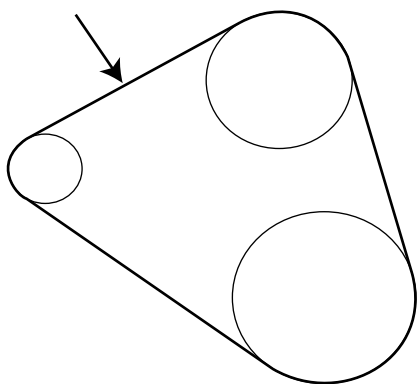

002598

Figure 4-5. Alternator Belt

2. Read the belt tension:
 - Correct new belt slack: 0.2–0.24 in (5.1–6.1 mm)
 - Correct used belt slack: 0.28–0.31 in (7.1–7.9 mm)
3. Replace the alternator drive belt if it is out of spec or is damaged. See engine manual for more information on adjusting the alternator belt.

NOTE: Belts must be replaced as a set. Otherwise, premature belt wear can result because of uneven belt length.

Maintenance Schedule

Periodic inspection, service, and maintenance of this unit is critical to ensure reliable operation. The following is the manufacturer's recommended maintenance schedule. Maintenance items will need to be performed more frequently if the heater is used in severe applications (such as very high or very low ambient conditions or extremely dirty/dusty environments). Use the heater hour meter or calendar time, whichever occurs first, from the previous maintenance interval to determine the next required maintenance interval. Note that some checks are based on hours of operation.

Follow all applicable safety alerts found in this manual or the engine manual before performing any maintenance checks or service.

This maintenance schedule reflects the minimum tasks that need to be accomplished to verify the heater remains operational. Some of the tasks can be performed by an authorized operator and others must be performed by a GMASD.

NOTE: An authorized operator is one who has been trained by a GMASD in proper operation and inspection of this unit.

Engine Maintenance Schedule

	Daily	Every 250 hr	Every 500 hr	Every 750 hr	Every 1,000 hr
Check engine oil level	•				
Inspect engine for fuel, oil, and coolant leaks	•				
Check oil pressure gauge registration	•				
Check oil pressure warning lamp	•				
Drain water in fuel filter	•				
Check coolant for abnormal color	•				
Check coolant level	•				
Check coolant temperature gauge	•				
Check alternator drive belt tension and replace if necessary	•		•		•
Inspect air cooler for water leaks	•				
Check engine malfunction indicator lamp and LCD Panel	•				
Check electrolyte level	•				
Clean battery	•				
Check battery charge condition – Ammeter registration – Charge warning lamp	•				
Check preheating condition	•				
Check engine starting condition	•				
Check exhaust smoke condition	•				
Inspect trailer for damage or corrosion	•				
Inspect trailer tires for wear or deflation	•				
Inspect overfill containment system for excessive fluid collection	•				
Inspect wheel bearings	•				
Replace fuel filter element*		•			
Drain water in fuel filter		•			
Replace engine oil and oil filter element			•		
Replace engine air filter			•		
Remove fan belt and check for ware.				•	
Inspect pulleys and bearings. Rotate and feel for hard turning or unusual sounds.				•	
Change hydraulic fluid					•
Replace hydraulic filters					•

Maintenance

Check and clean the starter and alternator					•
Check cylinder compression pressure*					•
Check valve clearance*					•
NOTE: After 1,000 hrs, all hours-based checks and maintenance should now be performed every 250 hrs.					
NOTE: For items marked *, consult equipment supplier.					

The following maintenance items should be performed annually, regardless of operation hours:

Annual Change	<ul style="list-style-type: none">• Hydraulic breather/separator• Carbon monoxide (CO) test at outlet air duct by trained service technician• Blower/fan hardware for condition and tightness
----------------------	---

NOTE: All service and maintenance or repairs are recommended to be completed by a GMASD to maintain the warranty status of a unit. You cannot be denied emissions warranty coverage solely based on failure to complete recommended service maintenance.

NOTE: For additional maintenance information, see the engine manual.

Battery Inspection



⚠️ WARNING

Explosion. Batteries emit explosive gases while charging. Keep fire and spark away. Wear protective gear when working with batteries. Failure to do so could result in death or serious injury.

(000137a)



⚠️ WARNING

Risk of burn. Do not open or mutilate batteries. Batteries contain electrolyte solution which can cause burns and blindness. If electrolyte contacts skin or eyes, flush with water and seek immediate medical attention.

(000163a)

⚠️ WARNING

Accidental Start-up. Disconnect the negative battery cable, then the positive battery cable when working on unit. Failure to do so could result in death or serious injury.

(000130)



⚠️ WARNING

Vision Loss. Eye protection is required to avoid spray from spark plug hole when cranking engine. Failure to do so could result in vision loss.

(000181)

⚠️ WARNING

Environmental Hazard. Always recycle batteries at an official recycling center in accordance with all local laws and regulations. Failure to do so could result in environmental damage, death, or serious injury.

(000228)

Always recycle batteries in accordance with local laws and regulations. Contact your local solid waste collection site or recycling facility to obtain information on local recycling processes. For more information on battery recycling, visit the Battery Council International website at: <http://batteryCouncil.org>

NOTE: See [Figure 4-6](#). Open controller door and remove 5 A fuse.

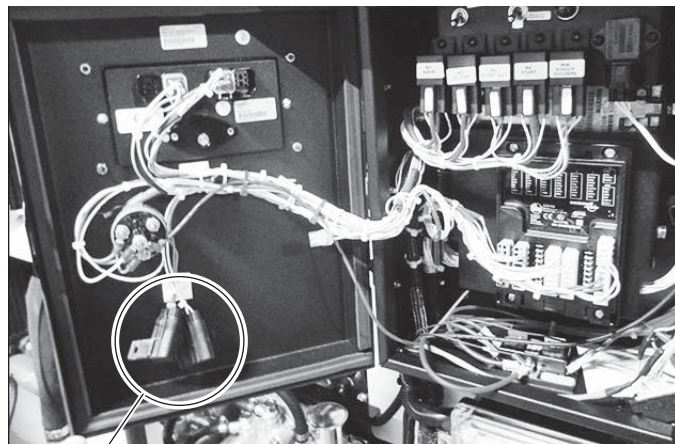

A

Figure 4-6. The 5 A fuse is housed by one of the indicated fuse holders (A).

An authorized operator should inspect the engine battery monthly. At that time, the battery fluid level should be checked using a load tester and distilled water added if needed. Battery cables and connections should also be inspected for cleanliness and corrosion.

NOTE: Replenish the battery with distilled water before operation. Replenishing the battery after operation does not allow the water to mix with the original electrolyte. The added water may freeze in adverse conditions.

A GMASD should inspect the battery system once every six months. At that time, the battery condition and state of charge should be checked using a load test battery. Recharge or replace the battery as required.

Battery service is to be performed or supervised by personnel knowledgeable of batteries and the required precautions. Keep unauthorized personnel away.

Observe the following precautions when working on batteries:

- Remove watches, rings, or other metal objects.
- Use tools with insulated handles.
- Wear rubber gloves and boots.
- Do not lay tools or metal parts on top of battery.
- Discharge static electricity before touching battery by first touching a grounded metal surface.
- Disconnect charging source prior to connecting or disconnecting battery terminals.

NOTE: Spilled electrolyte is to be washed down with an acid neutralizing agent. A common practice is to use a solution of 1 lb (454 g) bicarbonate of soda (baking soda) to 1 gal (3.8 L) of water. The bicarbonate of soda solution is to be added until the evidence of reaction (foaming) has ceased. The resulting liquid is to be flushed with water.

Battery Installation and Replacement



CAUTION

Equipment damage. Do not make battery connections in reverse. Doing so will result in equipment damage.

(000167a)

When required, the battery must be replaced with one of equivalent size, voltage, and CCA (cold crank amp capacity). Minimum CCA for this unit is 2200 (2 pairs of 2 1100 CCA 12 volt batteries in series to give 1100 amps at 24 volts connected in parallel to provide 2200 CCA at 24 volts). Contact a GMASD for correct battery size. A new battery must be filled with the proper electrolyte and be fully charged before install.

Battery cables are connected to the unit at the factory. Proceed as follows to connect cables to battery posts:

1. Connect red battery cable from starter contactor to positive (POS or +) battery post.
2. Connect black battery cable to negative (NEG or -) battery post.
3. See [Engine and Heater Startup](#).

Other Maintenance Checks

The following inspections should be performed by an authorized service technician, or a properly trained authorized operator. These maintenance items require a high level of experience and skill to evaluate and correct.

- Inspect engine accessory drive belts
- Inspect hoses and connections
- Inspect fuel supply system
- Inspect exhaust system
- Inspect exhaust pipe sleeve

Section 5: Troubleshooting

General Troubleshooting Guide

Problem	Cause	Solution
Engine cranks but will not start	No fuel.	Verify there is no fuel leakage and replenish.
	Low oil level.	Replenish oil to full. See Draining Fluids—Central Fluid Drain System .
	Emergency shutdown switch is ON.	Turn emergency shutdown switch OFF.
	Air in fuel system.	Purge air from system.
	Clogged fuel filter.	Remove water and change element. See Removing Water From Fuel .
	Fuel is gelled.	Warm fuel pipes with hot water or wait until ambient temperature rises.
	Faulty injection pump.	Contact a GMASD.
	Electromagnetic type fuel pump problem.	
	Engine control system problem.	
	Restricted air flow.	Check/replace air filter.
	LCD shows engine problem.	Contact a GMASD.
	Clogged strainer.	
Faulty pre-heating device.		
Engine will not crank (electric start)	Discharged battery.	Replace battery. See Battery Installation and Replacement .
	Battery terminal is disconnected, loose, or corroded.	Replace corroded part and tighten securely.
	Starter ground terminal is disconnected, loose, or corroded.	
	Excessive engine oil viscosity.	Change with oil of correct viscosity. See Draining Fluids—Central Fluid Drain System and Refilling Engine Oil .
	Starter or electrical system problem.	Contact a GMASD.

Engine starts but stops shortly thereafter	Insufficient idling.	Adjust by idling control equipment on the machine. If adjustment is not possible, contact ISUZU dealer.
	Clogged fuel filter.	Remove water and change element. See <i>Removing Water From Fuel.</i>
	Clogged pre-fuel filter.	Clean or change element.
	Clogged air cleaner.	
	Engine control system problem.	Contact a GMASD.
	Faulty injection pump.	
	Clogged strainer.	
Electromagnetic type fuel pump problem.		
Engine running is unstable	Fuel system problem.	Purge air or remove water. See <i>Removing Water From Fuel.</i>
	Water or air in fuel system.	
	Engine control system problem.	Contact a GMASD.

Problem	Cause	Solution
Exhaust smoke is white	Insufficient warm-up time.	Conduct warm-up operation.
	Excessive engine oil.	Correct oil level. See Draining Fluids—Central Fluid Drain System and Refilling Engine Oil .
	Engine control system problem.	Contact a GMASD.
	Faulty injection pump.	
	Fuel system problem.	
Exhaust smoke is black	Excessive speed.	Verify engine rpm. Check AVR adjustment.
	Faulty injection pump.	Contact a GMASD.
	Clogged air cleaner.	Clean or change element.
	Clogged intercooler.	Contact a GMASD.
	Fuel system problem.	
Clogged exhaust system.		
Engine overheats	No coolant.	Add coolant. See Adding Coolant .
	Front of radiator is clogged with dust.	Clean with soft brush.
	Sub tank cap is not tightened.	Tighten or replace sub tank cap.
	Fouled coolant.	Clean inside of radiator and change coolant. See Adding Coolant .
	Oil in coolant.	Contact a GMASD.
	Faulty thermostat.	Change thermostat.
Oil pressure does not rise	Incorrect engine oil viscosity.	Change with oil of correct viscosity. See Draining Fluids—Central Fluid Drain System and Refilling Engine Oil .
	Insufficient engine oil level.	Replenish oil. See Refilling Engine Oil .
	Engine problem.	Contact a GMASD.
	Meter, lamp, or switch problem.	
Engine has no power	Clogged air cleaner.	Clean element.
	Clogged pre-fuel filter.	
	Clogged fuel filter.	Remove water and change element. See Removing Water From Fuel .
	Clogged strainer.	Contact a GMASD.
	Engine control system problem.	
	Engine problem.	
	Clogged exhaust system.	
	Fuel system problem.	
	Incorrect fuel type.	
Electromagnetic type fuel pump problem.		

Problem	Cause	Solution
Overheat/shutdown condition	Access doors are open.	Close all access doors.
	Air outlets are closed.	Open the air outlets and verify there are no obstructions or extreme bends in the ducting.
	Front radiator or rear oil cooler are full of debris.	Clean the machine.
	Excessive engine rpm based on ambient temperature.	Lower the engine rpm.
	Faulty temperature sensor.	Check air outlet sensor operation.
	Blower fan operating incorrectly.	Remove ducting; check blower fan operation.
No/low heat condition	Incorrect heater setting (target temperature too low).	Adjust heater output. See Adjusting Heater Output .
	Access doors are open.	Close all access doors.
	Low HTF/hydraulic oil level.	<ul style="list-style-type: none"> • Check level on tank sight glass, adjust as needed. • Inspect HTF hoses for leaks or loose fittings. • Check fluid for foaming.
	Clogged HTF/hydraulic oil filters.	Check restriction gauges/replace HTF filters.
	Excessive ducting for ambient conditions.	Move unit closer to heat recipient if possible.
	HTF pump drive sheared.	Contact a GMASD.

Digital Controller Status Messages

Message	Cause
Engine Warming – Please Wait	Engine coolant temperature < 140 °F (60 °C)
Engine Preheat	Wait approximately 10 seconds after heater power up
Engine is not ready – Check rpm, Fuel Level, or Wait to Start	Engine rpm < 500
	Fuel level < 10%
	Wait to Start signal
Low Fuel Warning	Fuel level < 20% <ul style="list-style-type: none"> • Fuel level notification appears on screen
	Fuel level ≤ 16% <ul style="list-style-type: none"> • Fuel level notification appears on screen • Heat/fan load reduced to 50%
	Fuel level ≤ 12% <ul style="list-style-type: none"> • Fuel level notification appears on screen • Open heat circuit and close scroll fan circuit • Drop engine to idle
	Fuel level ≤ 8% <ul style="list-style-type: none"> • Fuel level notification appears on screen • Engine shuts down
Check heater settings or connections, then Reset on the Machine Overview	IFM controller detected a short or break in a sender
Heater is cooling down – Please wait	IFM controller detects heater is in cool down. ON button disabled.
Engine is going to shutdown	Fuel level ≤ 12% for 3 hours and 15 minutes
Engine Fault Shutdown	Low engine oil pressure
	High engine coolant temperature
	Engine overspeed
Heater shutdown due to temperature, pressure or level out of range	High hydraulic temperature
	Low hydraulic pressure
	Low hydraulic level
Fuel over temp.	Fuel temperature ≥ 140 °F (60 °C) <ol style="list-style-type: none"> 1. Open heat circuit solenoid 2. Increase scroll fan rpm to max rpm via fan circuit solenoid and drop engine to idle 3. Monitor fuel temperature for five minutes
	Fuel temperature is still ≥ 140 °F (60 °C) <ol style="list-style-type: none"> 1. Open heat circuit solenoid 2. Drop engine to idle 3. Unit will shut down after five minutes

This page intentionally left blank.

Section 6: Installation Diagrams and Service Log

Engine Harness (1 of 3)

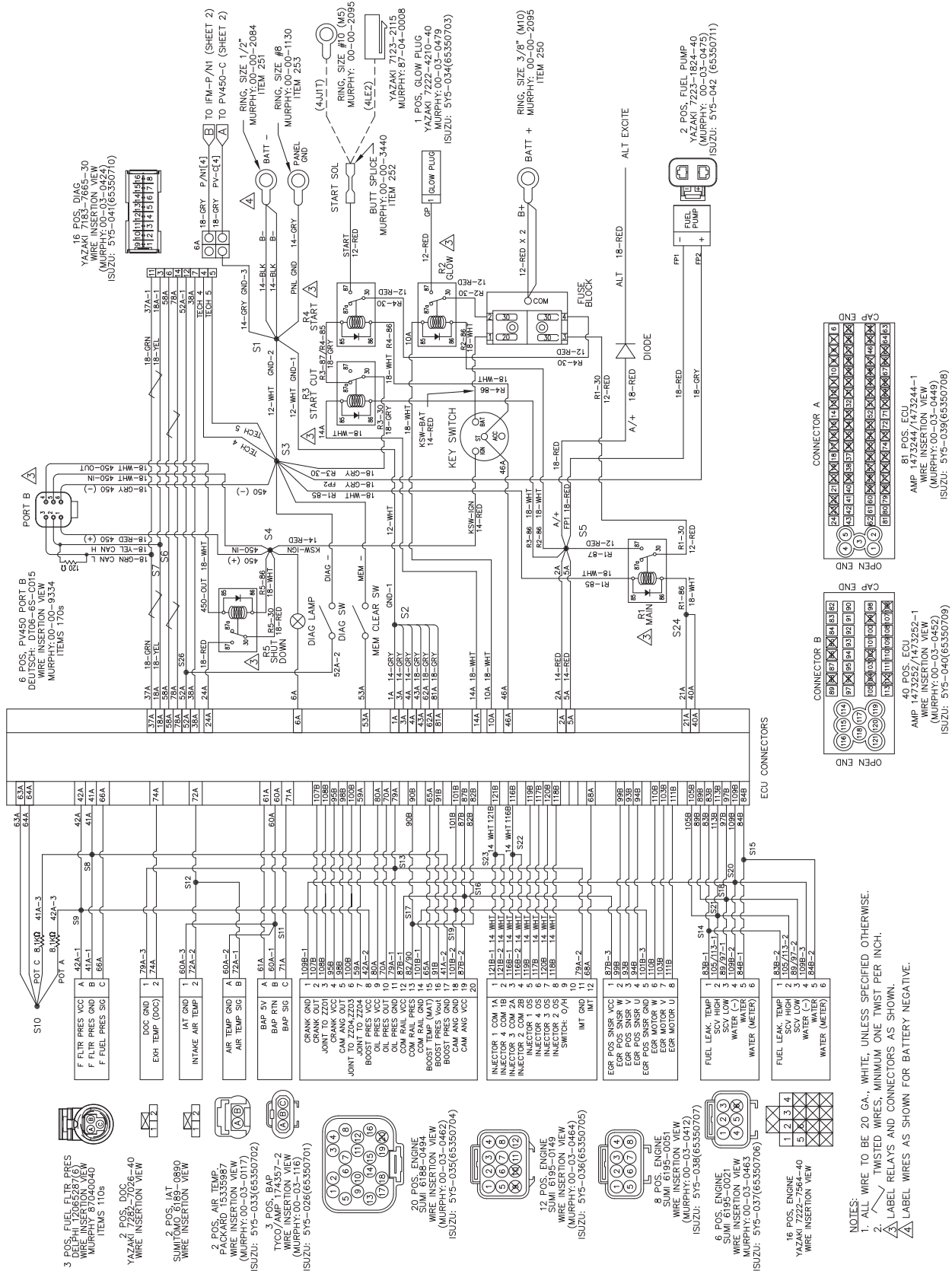

- NOTES:**
1. ALL WIRE TO BE 20 GA., WHITE, UNLESS SPECIFIED OTHERWISE.
 2. TWISTED WIRES, MINIMUM ONE TWIST PER INCH.
 3. LABEL RELAYS AND CONNECTORS AS SHOWN.
 4. LABEL WIRES AS SHOWN FOR BATTERY NEGATIVE.

Engine Harness (2 of 3)

- NOTES:
1. ALL WIRES ON SHEET 2 TO BE 18 GA. WHITE, UNLESS SPECIFIED OTHERWISE.
 2. TWISTED WIRES, MINIMUM ONE TWIST PER INCH.
 3. SHIELDED CABLE.
 4. LABEL CONNECTORS AS SHOWN.
 5. FUSE 7 & 8 LOCATED ON THE REAR OF THE PANEL DOOR.

IFM PORT A

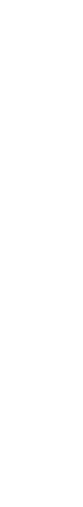
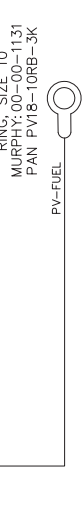
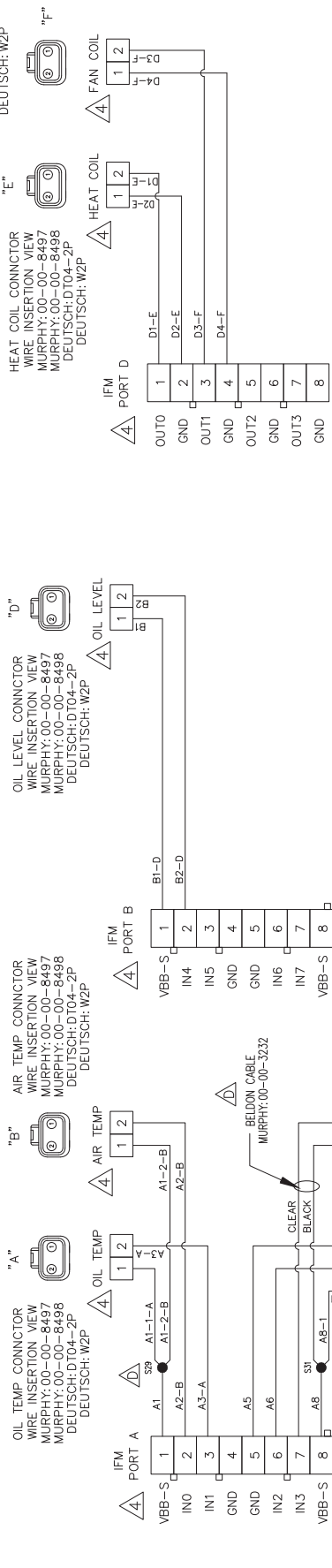

Engine Harness (3 of 3)

NOTES:

1. = 1/4" LOOM (00002874).
2. DRAWING IS NOT TO SCALE.
3. ALL DIMENSIONS ARE IN INCHES.
4. TAG WIRE ENDS OR CONNECTOR WITH LABELS SHOWN.
5. LOOM SHOULD START ATLEAST 3" FROM INSIDE OF THE PANEL.
6. LABEL CONNECTORS AS SHOWN.
7. USED ONLY FOR 4LE2 ENGINE.
8. USED ONLY FOR FT4 4JJIT ENGINE.
9. UNUSED CONNECTORS SHOULD BE COVERED WITH SHRINK TUBE AND TIDE BACK TO LOOM SECURELY.

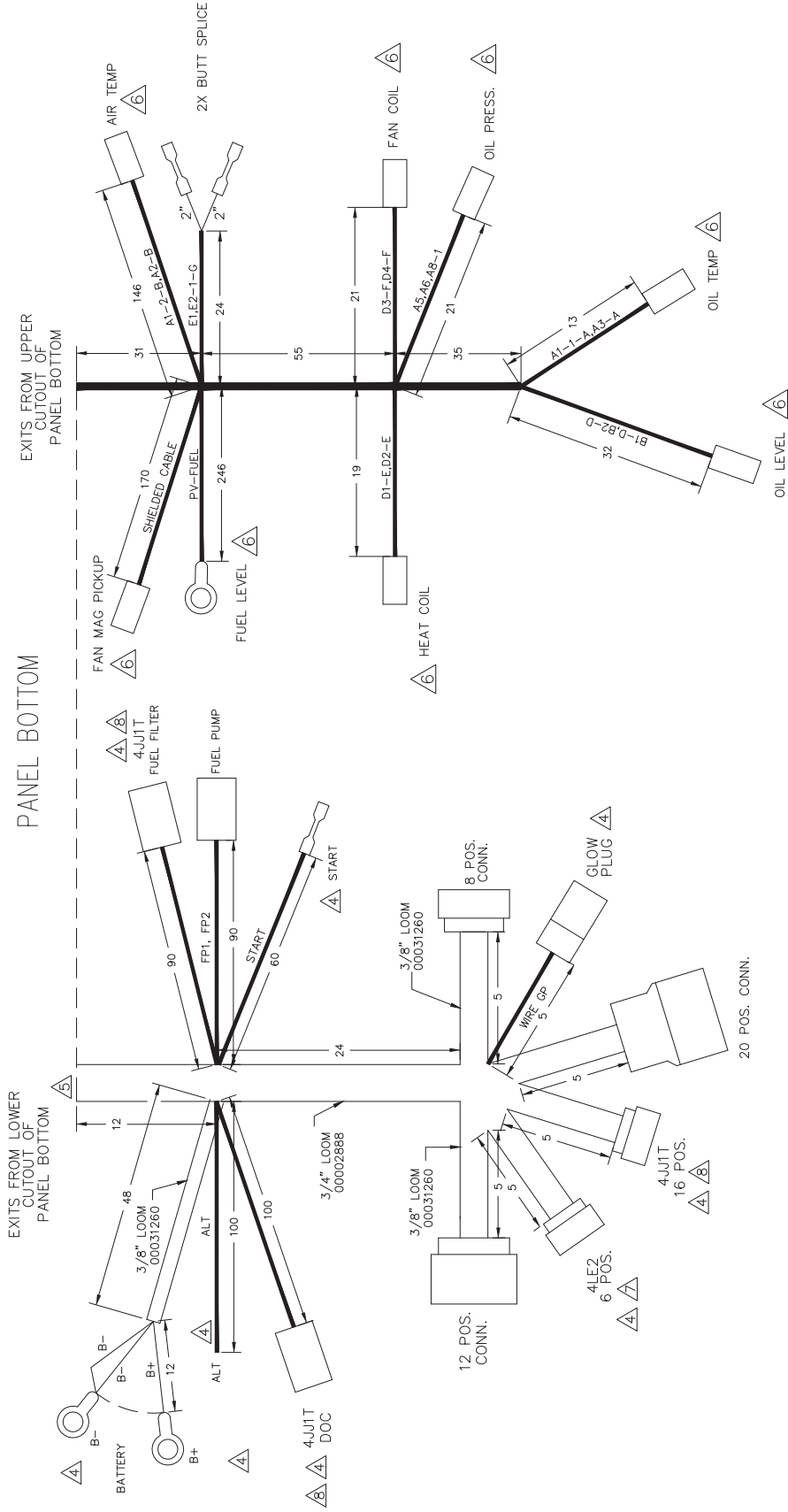

Trailer Wiring Harness

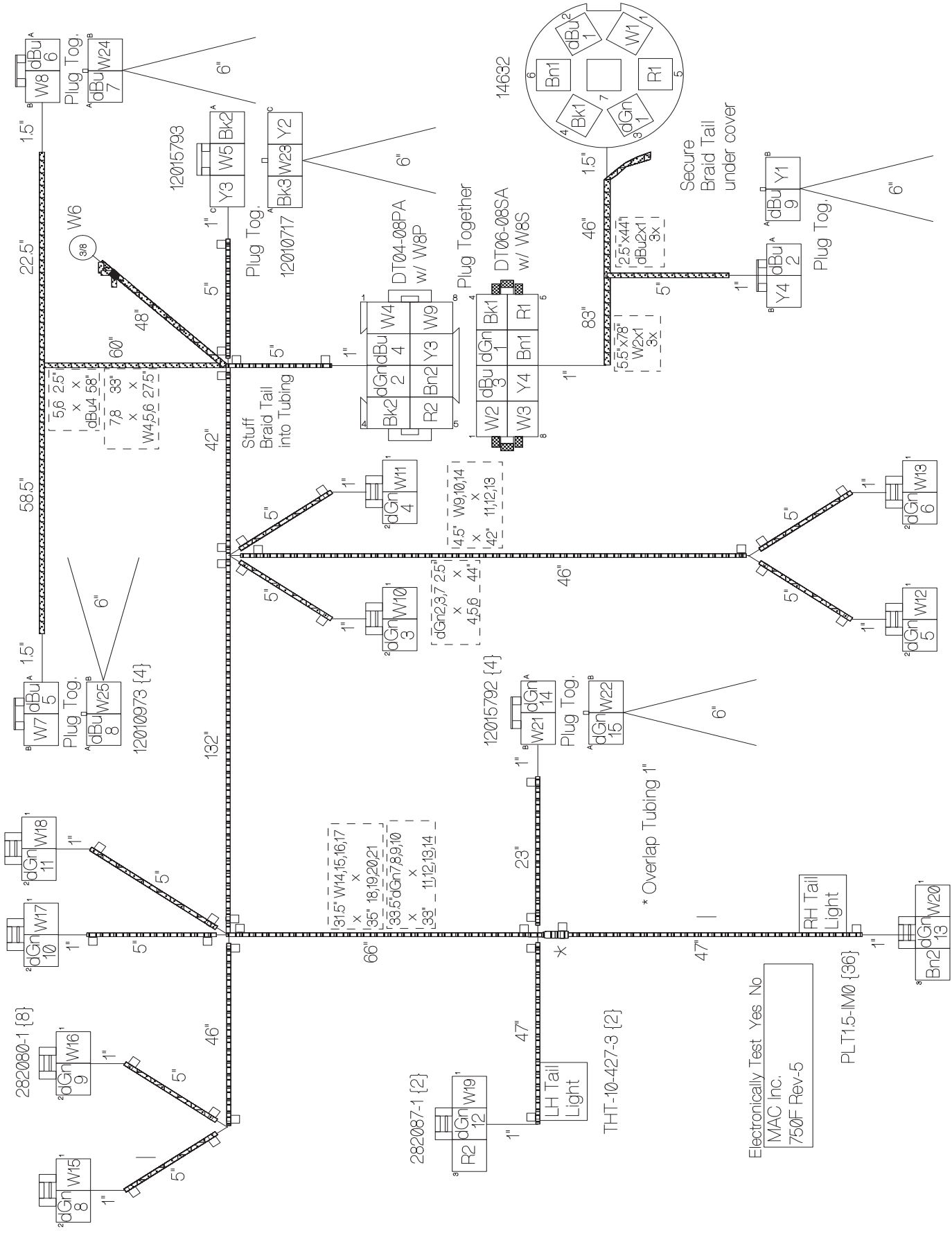

Electrically Test Yes No
 MAC Inc.
 750F Rev-5

Service Log

OIL GRADE: _____ BRAND: _____

COOLANT MIXTURE: _____ BRAND: _____

Date	Hours to Service	Oil Level	Coolant Level

Date	Hours to Service	Oil Level	Coolant Level

This page intentionally left blank.

Part No. A0000244024 Rev. A 10/14/2019

©2019 Generac Mobile Products, LLC

All rights reserved.

Specifications are subject to change without notice.

No reproduction allowed in any form without prior written consent from Generac Mobile Products, LLC.

GENERAC | **MOBILE**

Generac Mobile Products, LLC
215 Power Drive, Berlin, WI 54923

GeneracMobileProducts.com | 800-926-9768 | 920-361-4442